

INSTALLATION
INSTRUCTIONS

ZONE EXPANDER ZX- 6

DOORGUARD SYSTEMS, INC.

8970 - D ROUTE 108

COLUMBIA, MD 21045

1-800-442-6247

FAX (410) 992-5694

Email: info@doorguardsystems.com

STEP 1

PRELIMINARY PROCEDURES

- A. Ensure that all DOORGUARD time delay magnetic locks have been properly installed as per factory installation procedures.
- B. Referring to Figure 1, select a location for the Zone Expander centrally located to the doorGuard magnetic locks.
- C. Determine how the Magnetic Lock Assembly-to-Zone Expander and Zone Expander-to-Sentry Station wiring is to be run, surface wiring or concealed wiring (in the wall), and make appropriate installations.

STEP 2

MOUNTING THE ZONE EXPANDER

- A. Using the four mounting holes located in the corners of the enclosure, mount the enclosure on the wall using the four #12 x 1" long screws supplied. Mount enclosure with the large round air flow outlet toward the ceiling.

NOTE: DO NOT MOUNT IN AN AREA WHICH WOULD RESTRICT AIR FLOW THROUGH THE FRONT COVER OR THE TOP OUTLET.

STEP 3 WIRING CONNECTIONS

Figure 1

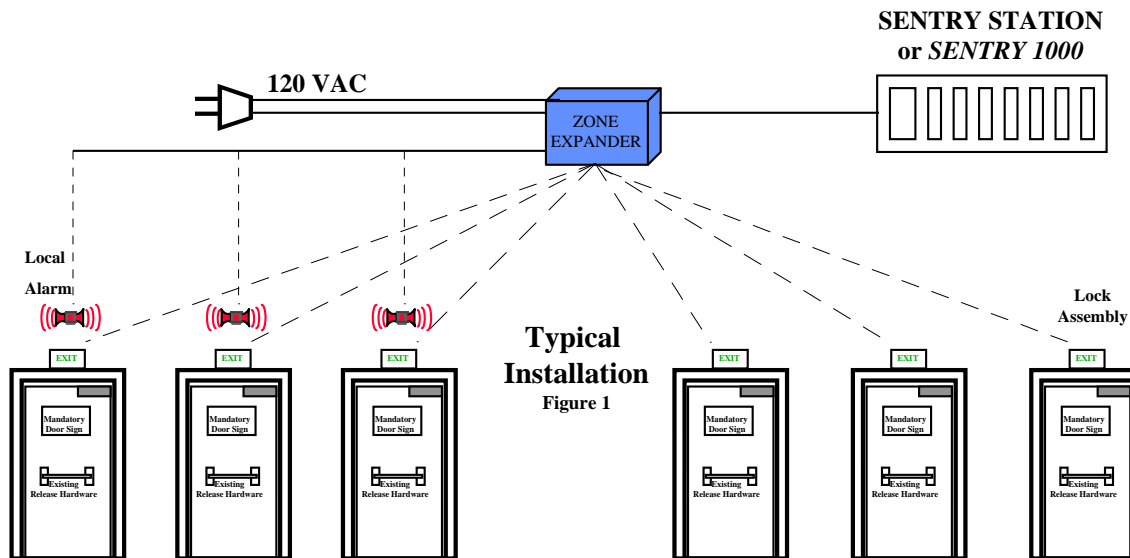

A. Referring to Figure 2.1, and 2.2 route a 6-conductor 18 gauge cable from each Magnetic Lock Assembly to the Zone Expander. It is recommended that these cables be concealed or protected and that they do not exceed 100 feet per Magnetic Lock.

NOTE: Figure 2.2 Wiring Diagram illustrates Zone Expander Connection to the SSA/SSB Sentry Station. For wiring connections to the new Sentry 1000, refer to Figure 2.1.

FIGURE 2.1

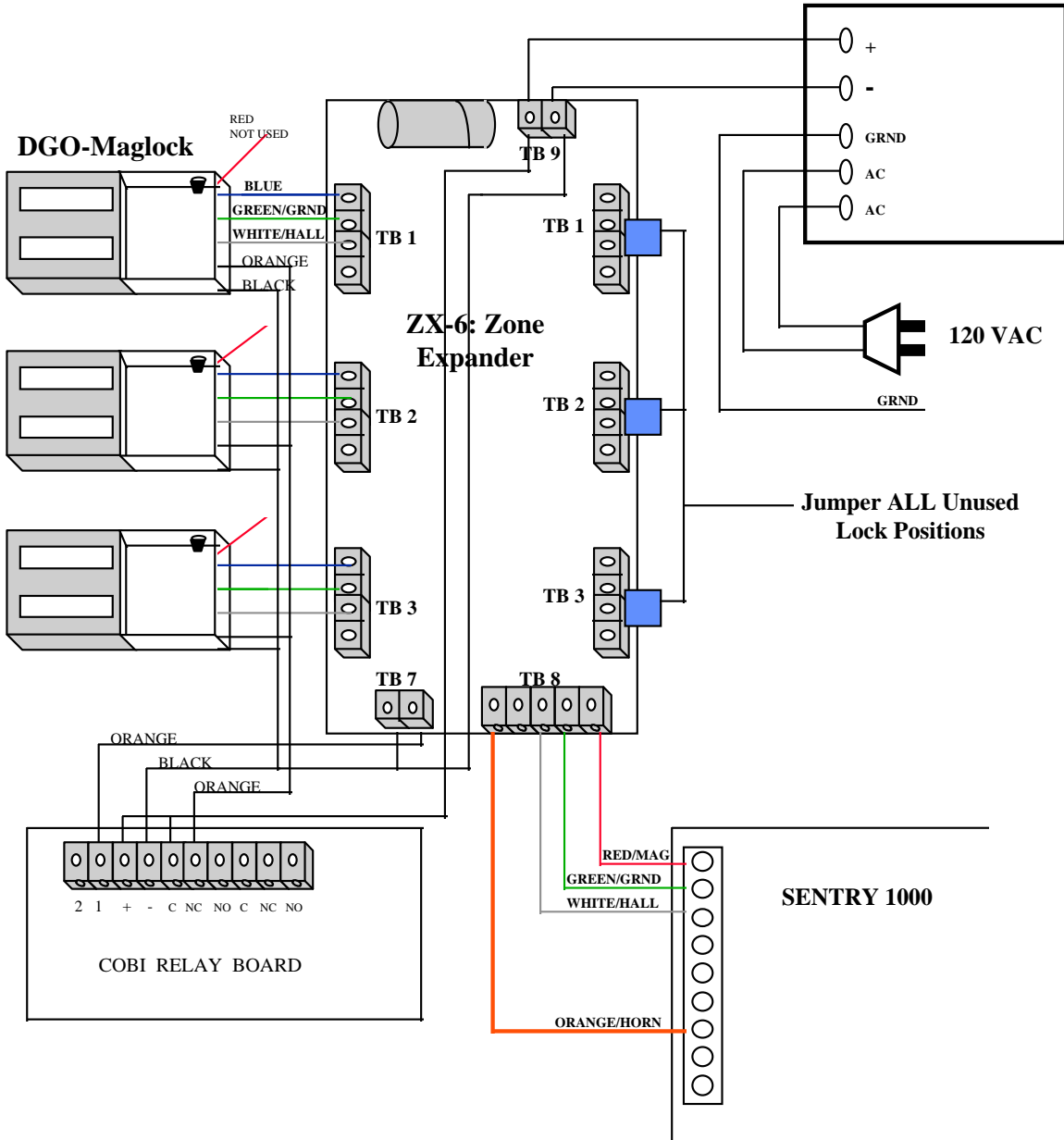

B. Referring to Figure 2, dress and connect three wires from each magnetic lock to the Zone Expander circuit board using terminal blocks TB 1 through TB 6. The Zone Ex-

pander will accept from 1 to 6 magnetic locks. Any unused lock position (TB 1 through TB 6) must contain a jumper wire between “GRN (GND)” and “WHT (HAL)” for proper operation. Accordingly, remove factory installed jumper wire for each active lock connection.

C. Route a 4-conductor, 18 gauge cable from the Zone Expander to the Sentry Station. Refer to Figure 2.2. Do not connect at this time.

NOTE: Maximum run from Zone Expander to the Sentry Station is 1000 feet. For longer wire runs, call the factory.

Figure 3

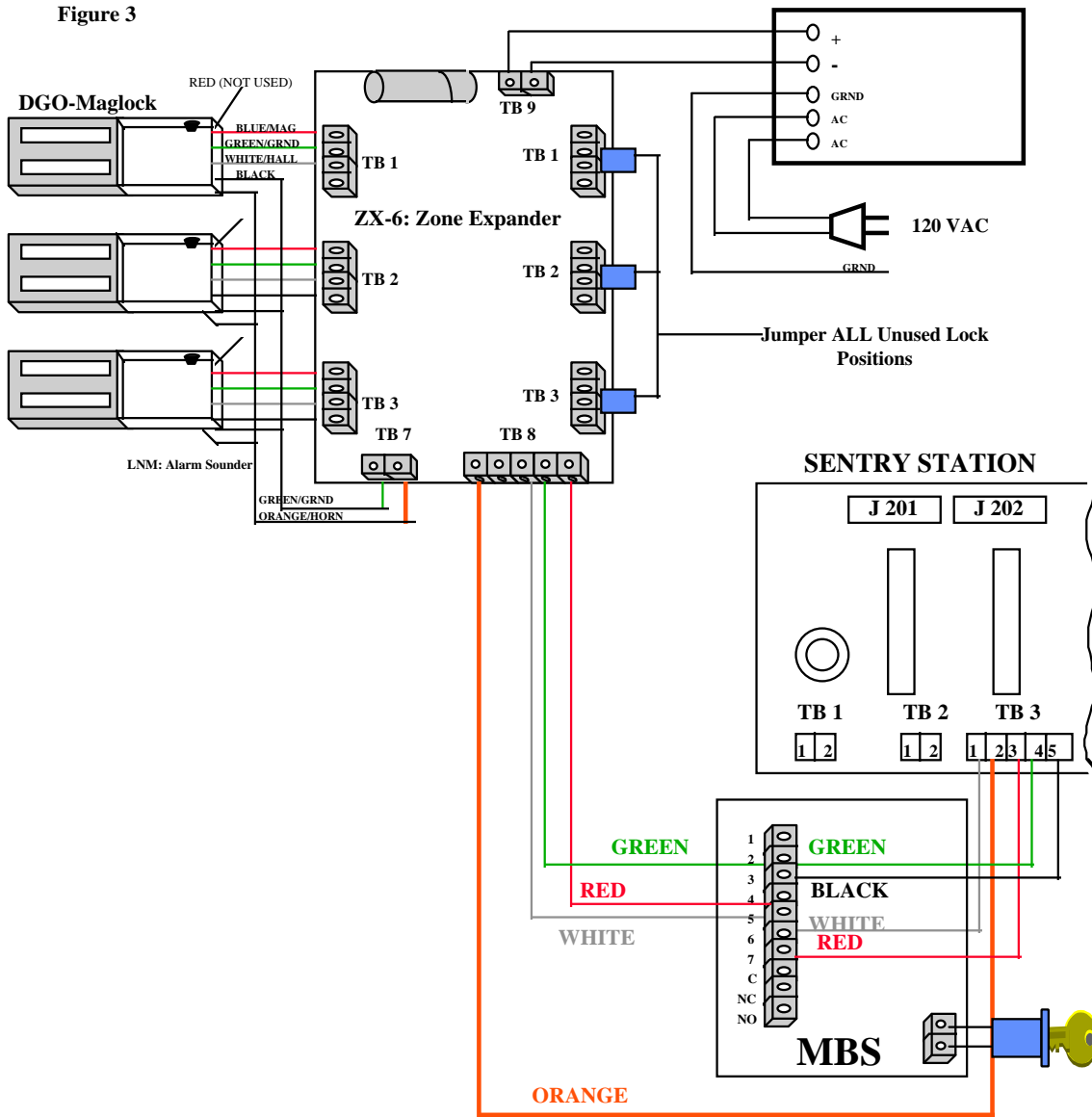

FIGURE 2.2

Figure 4

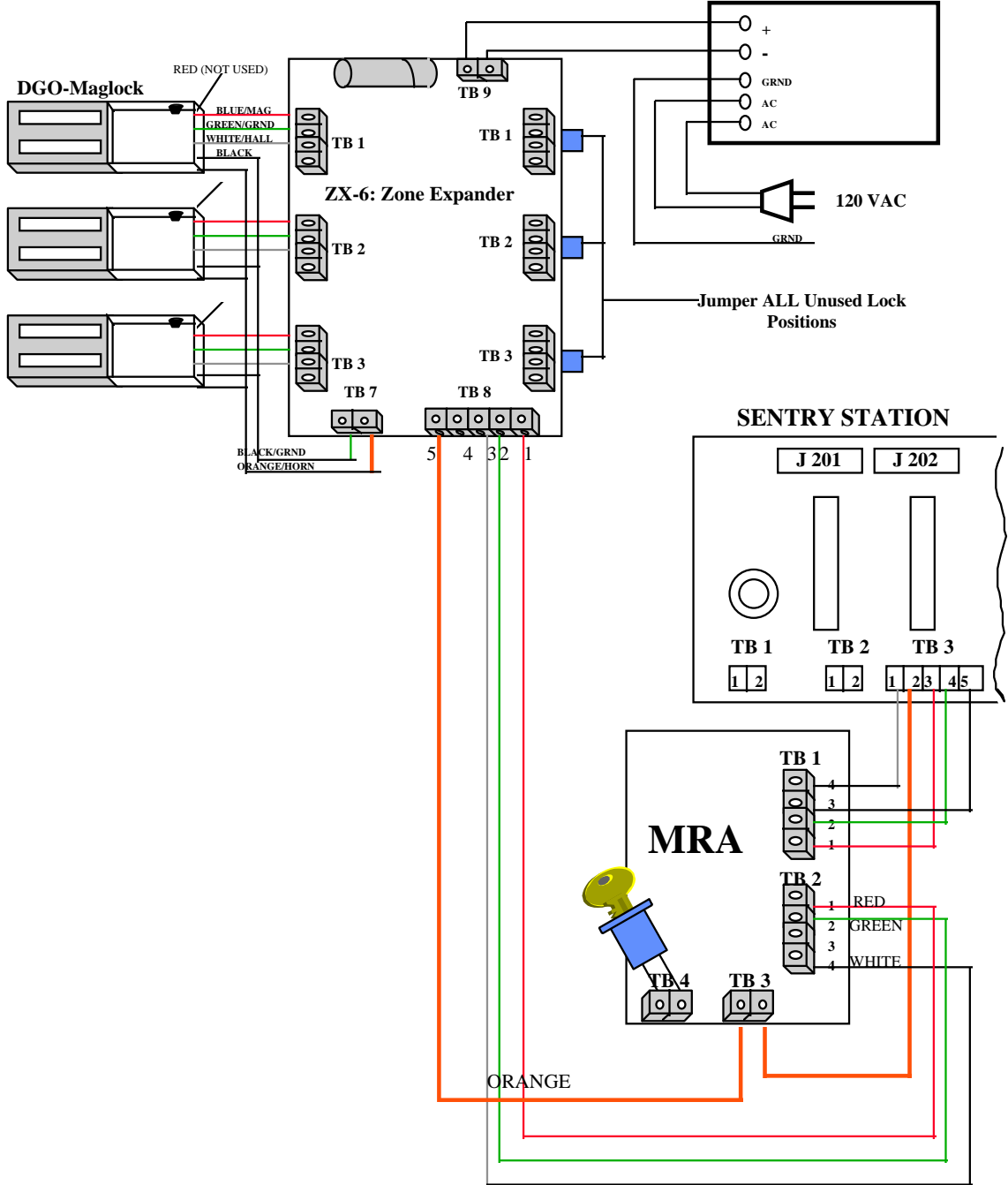
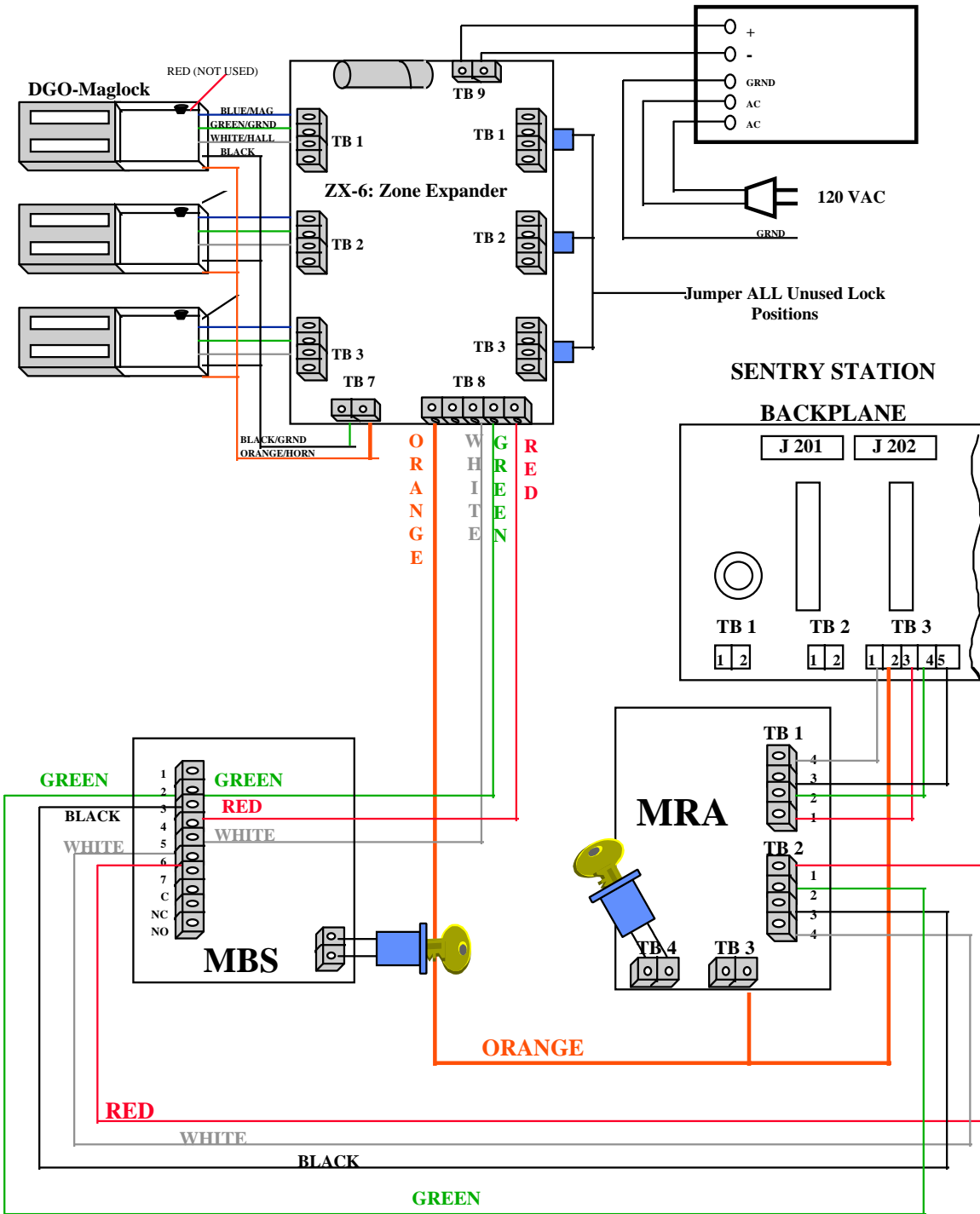

Figure 5



D. If a Momentary Bypass (MBS) and/or Manual Relock (MRA) is to be used with a Sentry Station, refer to figures 3, 4, & 5 for proper wiring configurations.

NOTE: DO NOT apply 110 VAC power at this time.

E. Connect a power cord to the power supply located in the Zone Expander enclosure; Black to AC Hot, White to AC Neutral, and the Green wire to AC Ground. Refer to Figures 2., 3, 4, and 5.

STEP 4

CHECKOUT PROCEDURE

The following procedure will test the function of the Zone Expander and the activator assembly (trigger mechanism) of the DOORGUARD time delay magnetic locks.

A. With the power disconnected from both the Sentry Station and the Zone Expander, hold or prop open all doors connected to the Zone Expander, so that the Armature Assemblies are completely disengaged from the Magnetic Locks.

NOTE: The involvement of two individuals will be helpful for checking out the Zone Expander installation. One person should operate the doors and one check the LED displays in the Zone Expander.

B. Apply 120 VAC Power to the Zone Expander only. Sentry Station Power should be off during this procedure.

C. Observe the LED indicators on the Zone Expander's printed circuit board. All LEDs corresponding to nonactive lock positions should be lit. For example, if three positions TB 4, TB 5, and TB 6 are jumpered and not used, their corresponding LEDs should be lit. If any of these three LEDs are not lit, recheck jumper connections.

D. The LEDs corresponding to the active lock terminal positions TB 1, TB 2, and TB 3 should not be lit. If any of these active positions are illuminated, check the following:

1. Ensure that door is propped open.
2. Check wiring from magnetic lock to Zone Expander.

E. Activate the lock by positioning a small magnet on the face of the lock. The corresponding LED display on the Zone Expander should react by lighting with the lock activated by the magnet, and turning off with lock de-activated by removing the magnet from the face of the lock. If LED fails to react to magnet activation, check wiring as per above procedure (D2).

F. Remove 120 VAC power from Zone Expander.

- G. Close all doors so that armature plates are positioned against the magnetic locks.
- H. Again apply 120 VAC power to the Zone Expander. The locks will energize and the corresponding LEDs should light. If all LEDs are lit, proceed to step I. If any of the LEDs are not lit, adjustments must be made to the corresponding activator assemblies by following the procedure as stated in the Activator Adjustment.
- I. With all magnetic locks energized and all LEDs lit, push on each door's hardware locking mechanism (panic bar, crash bar, etc.). The door should move outward about 1/4 in. to 3/8 in. before the strike plate restricts outward movement. As the door moves outward, the activator will cause the LED to extinguish. If the LED does not extinguish make the adjustment as stated in the Activator Adjustment. Refer to the following section : Activator Adjustment.

FINISHING UP

- A. With all magnetic door locking mechanisms adjusted properly, the Zone Expander is ready to be connected to the Sentry Station.
- B. Remove 120 VAC power from the Zone Expander.
- C. Remove the temporary jumper from TB 8
- D. Referring to Figure 3, dress and connect four 18 gauge wires from TB 8 of the Zone Expander to the appropriate zone of the Sentry station (TB 3, TB 4, etc.).
- E. Close cover on Zone Expander and secure with screws supplied.

ACTIVATOR ADJUSTMENT

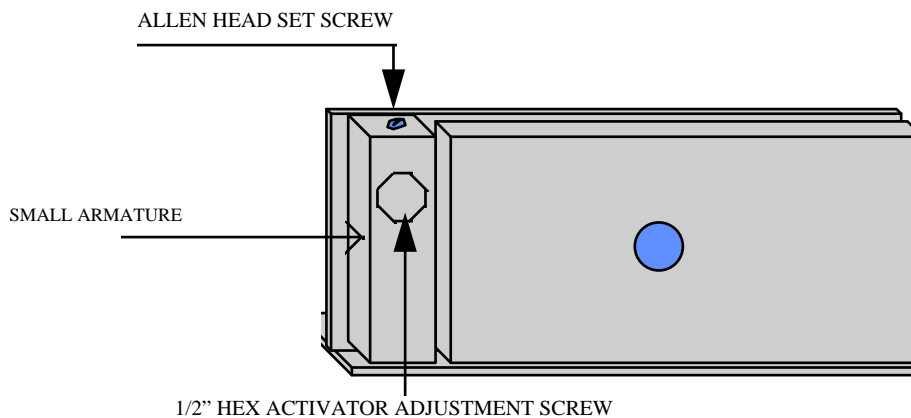

THEORY OF ADJUSTMENT

When the door is closed and latched, the magnet in the 1/2" hex screw on the small armature activates, signaling a secure status of the lock. When an attempt is made to open the door, the door is allowed to move outward, letting the activator change states. It is the movement of the door which signals the timing electronics that an attempt to open the door is being made. If the hex screw is not allowed to move away far enough, the door will not go into alarm. If the hex screw is not close enough to the lock when the door is closed, the unit will signal a false alarm.

- A. If the unit will not secure, or continuously goes into false alarm, then the activator adjustment screw must come further out from the small armature.
 - 1. Remove power from the system to release the magnetic lock.
 - 2. Referring to the activator adjustment diagram, loosen the Allen head set screw on top of the small armature that houses the 1/2" hex screw.
 - 3. Adjust the 1/2" hex screw **OUTWARD** in half turn increments. Repeat the testing procedure and resecure the set screw when complete.

- B. If the unit will secure but will not go into alarm and release the door, then the activator adjustment screw must go further in the small armature.
 - 1. Remove power from the system to release the magnetic lock.
 - 2. Referring to the activator adjustment diagram, loosen the Allen head set screw on top of the small armature block and adjust the 1/2" hex screw **INWARD** in half turn increments.

This document was created with Win2PDF available at <http://www.win2pdf.com>.
The unregistered version of Win2PDF is for evaluation or non-commercial use only.
This page will not be added after purchasing Win2PDF.